

GROVE[®]

GMK5130-1

▶ product
guide

 130 tonnes

 60 m

 11 - 32 m

 95 m

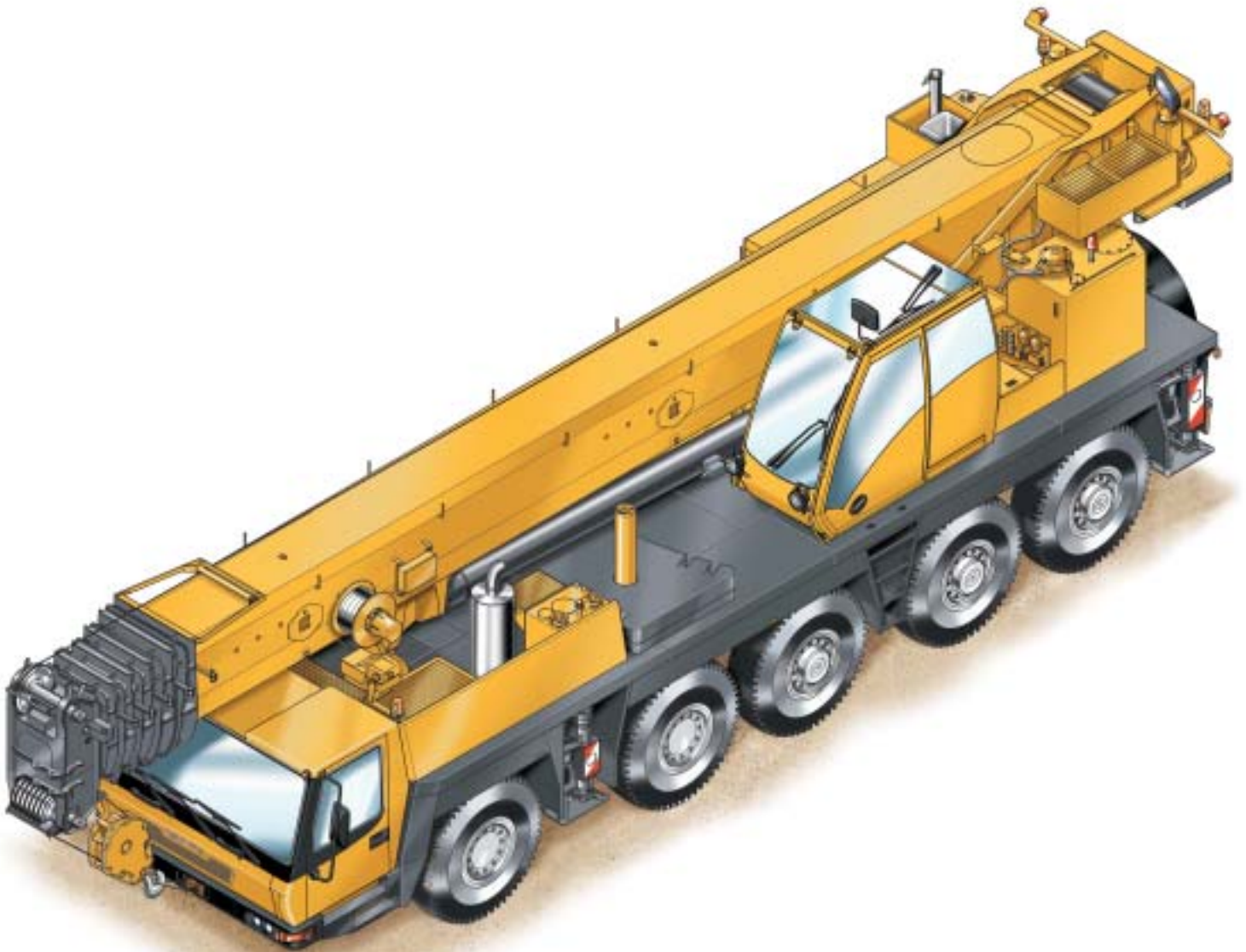

All-Terrain Crane • AT-Kran • Grue Automotrice Routière
Grúa Todo Terreno Rapida • Gru Fuoristrada Veloci

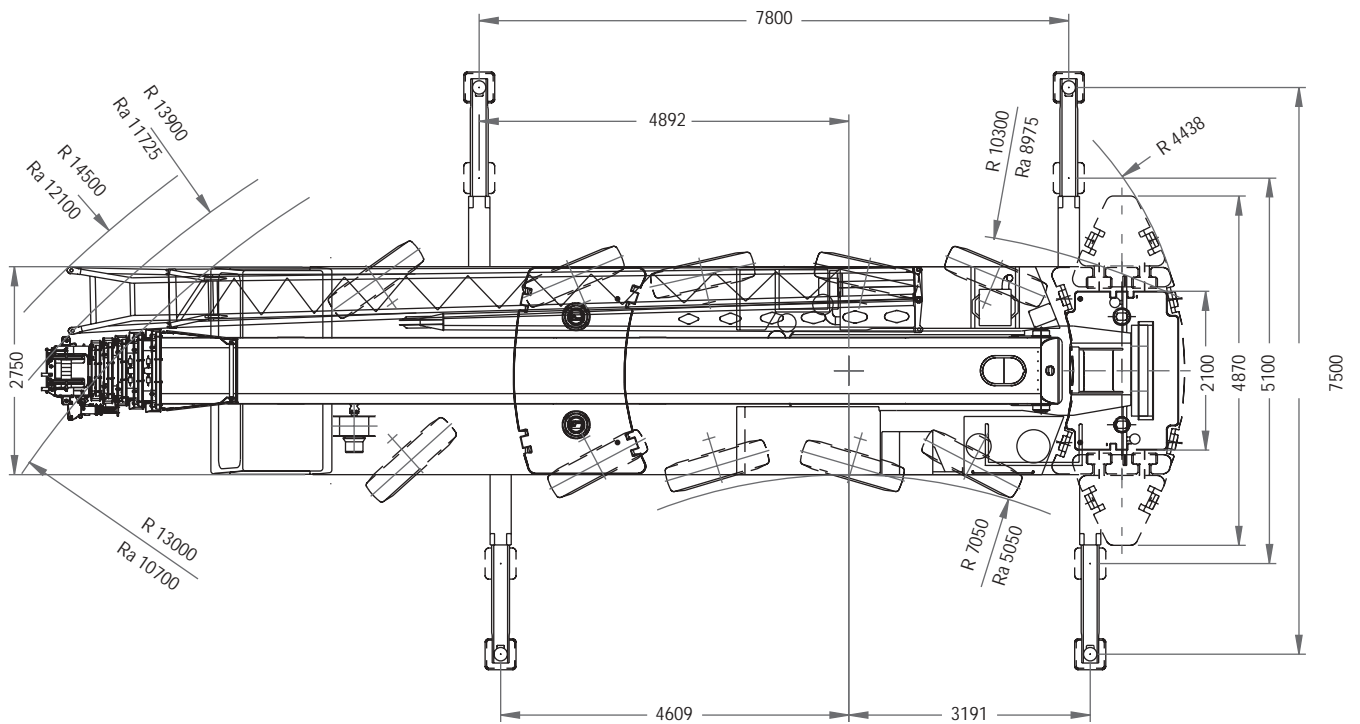
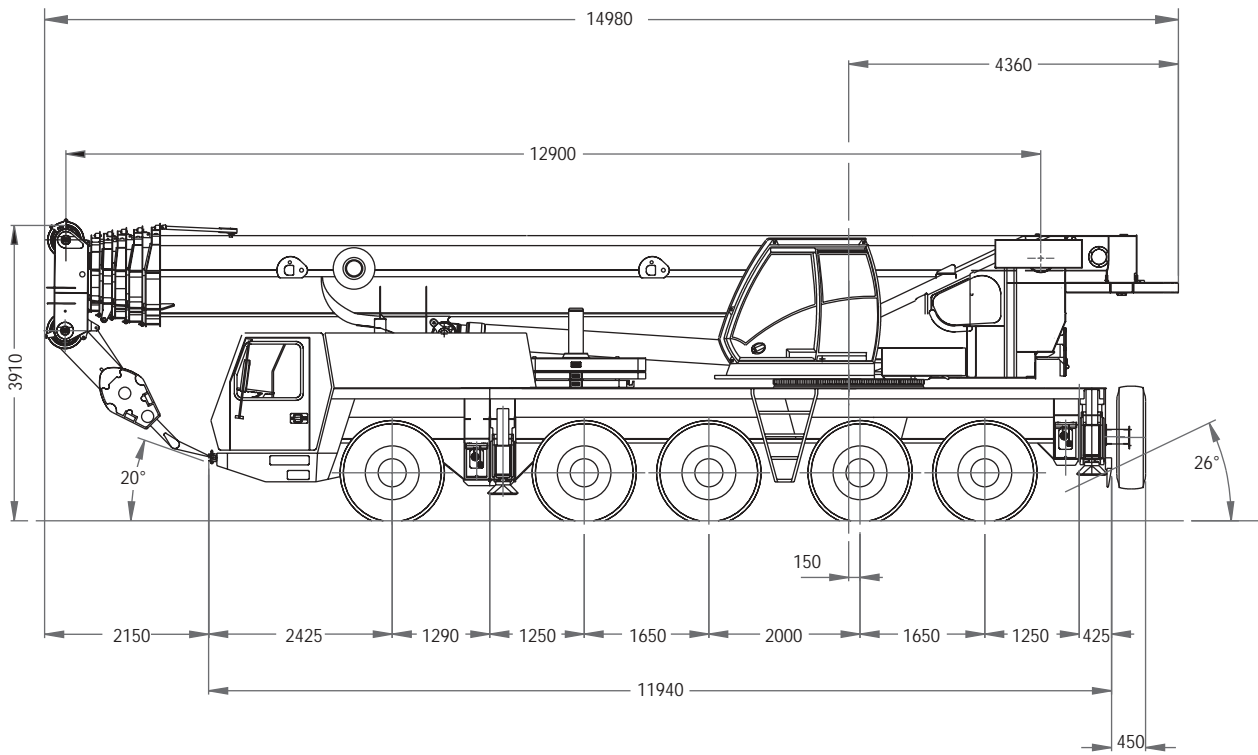

Ra = Radius all wheels steered
 Radius allradgelenkt
 Rayon toutes les roues directrices
 Radio de giro con todas las ruedas giradas
 Raggio di curva con tutte le ruote sterzate

14



12,9 – 60,0 m



11/18/
26/32 m



7,5 m



360°

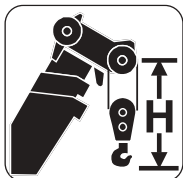
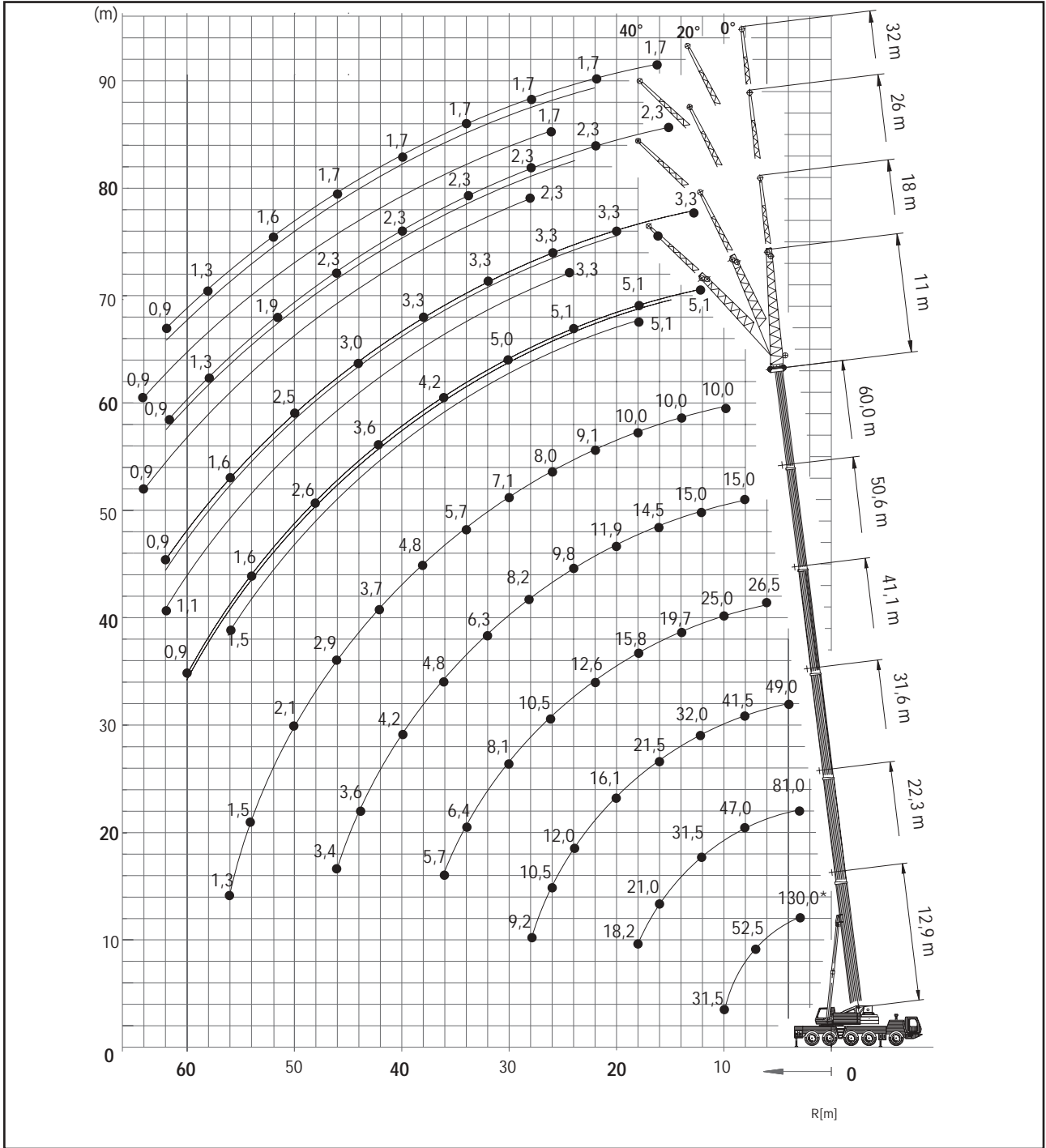

Hook block • Unterflasche • Crochet-moufle • Gancho • Ganci
(t)

120 D	H (mm)
100 D	3160
75 D	3160
50 E	3070
20 E	3000
8 H/B	2770
	2350

GMK5130-1